

## CURRENT LOOP (4-20 mA) OUTPUT

The Slick Sleuth Current Loop Output Option is used to provide monitoring and alarm notification to industrial SCADA/PLC supervisory systems. The advantage over using dry contacts is that the accuracy of the signal is not affected by voltage drop in the interconnect wiring even over moderately long distance. The Current Loop Interface can be used in either hardwire or wireless telemetry configurations.

In hardwire applications the typical distance of 1,200 meters can be expected for most conditions. This distance will vary depending on the circuit resistance including the resistance of the wire. The specified resistances for the current loop transmission distances are: Source Mode 650 ohm maximum resistance and Sink Mode 1,000 ohm maximum resistance.

For Slick Sleuth's equipped with the Current Loop Interface the signal transmitted through the current loop interface is in one of the following formats. The users must indicate which interface is preferred for their specific requirements so the unit(s) may be properly configured prior to shipping. If desired the user may switch to an alternate interface as required.

### 1. Discreet (Yes/No) Output

Yes/No output means that oil is reported as either 'present' or 'not present'. This determination is based upon background and threshold levels established by user during routine setup of the Slick Sleuth. There are also output levels to indicate 'fault' status. With the "Yes/No" protocol:

- 3 mA = Indicates 'Fault' (equipment/power system out of specification or faulty)
- 6 mA = Indicates 'NO Oil Detected', & 'monitor OK'
- 20 mA = Indicates 'YES Oil Detected', & 'monitor OK'

The Slick Sleuth monitor will maintain output level for the last condition reported, until a new condition is detected and reported at the corresponding output level. During normal operation the monitor will set the output at a nominal 6 mA, and hold the output at 6 mA indefinitely or until a change of conditions. If a positive 'Yes' detection is made, the output is set to a nominal 20 mA and held at 20 mA until there is no longer oil present or until a fault occurs. If oil is no longer present the output returns to a nominal 6 mA.

### 2. Scaled Output

Scaled output means that output is scaled proportionally to the signal strength (amount/type) of oil detected. This detection protocol is for users who want the signal to reflect the actual reading or raw number of "counts". As with both protocols, the monitor maintains output level for the last condition reported, until a new condition is detected and reported at the corresponding output level. With the "Scaled Output" protocol:

- 4-20 mA = Output is proportional to the fluorescence signal returned from any oil present - with 4 mA representing 'No Return', and a nominal 20 mA representing 'Full Scale Return'.
- < 4 mA = Less than 4 mA indicates 'Fault' (equipment/power system out of specification or faulty)

### 3. Scaled / Corrected Output

The data format is the same as the Scaled Output except that the ambient (or background) signal is subtracted from the signal before it is output on the current loop interface. The correction is the baseline measurement made during initialization or as measured by the adaptive baseline, if enabled.

### Source or Sink Configuration

When selecting the Current Loop Output Option users also specify whether they prefer to 'Source' the current loop output or 'Sink' with current loop output. The default factory setting is **Source**. The user may switch to the alternate setting as required.

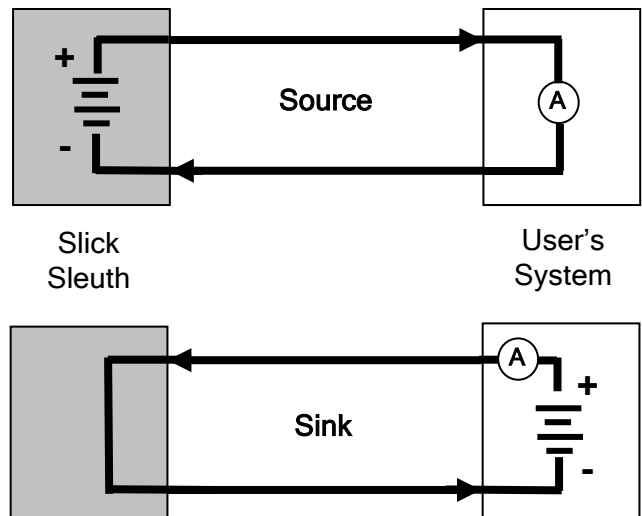

**Source Configuration** - DC is supplied by the Slick Sleuth Current Loop Output Board, which outputs current to the load monitoring device in the control room. Slick Sleuth is typically used in source mode.

**Sink Configuration** - DC is supplied by the user's monitoring/control system and the Slick Sleuth Current Loop Output Board "sinks" the current. Although Slick Sleuth is not typically used in sink mode it depends on the specific application.